



Analysis of signals from inductive sensors by means of the DasyLab software

Tadeusz Złoto^{1*}, Paweł Ptak^{2†}, Tomasz Prauzner^{3‡}

¹*Institute of Machine Technology and Automation of Production,
Częstochowa University of Technology
Armii Krajowej 21, 42-201 Częstochowa, Poland*

²*Institute of Telecommunications and Electromagnetic Compatibility,
Technical University of Częstochowa
Armii Krajowej 13/15, 42-218 Częstochowa, Poland*

³*Institute of Technical Education and Safety Jan Długosz University
Armii Krajowej 17, 42-218 Częstochowa, Poland*

Abstract – The paper deals with the acquisition of measuring signals from inductive sensors and their treatment in the programming environment National Instruments DasyLab. Its potential is presented with respect to analyzing and processing the data and the methods of constructing algorithms for performing complex tasks are discussed.

Signals coming from inductive sensors are typically sinusoidal or deformed, of irregular shapes. They carry various types of information: on the thickness of the outer coating, on the flaws in the coating, or on the linear or angular displacement.

In order to obtain such information from the measuring sensor it is necessary to examine the amplitude, frequency, or shape of the measuring signal analysed. Such signals can be examined as individual impulses of various shapes or as sets of periods extending over longer time spans.

The paper also describes the examples of the systems in the DasyLab software package to be used in measurements and other forms of applied research.

*zlotot@o2.pl

†p.ptak@o2.pl

‡matompra@poczta.onet.pl

1 Introduction

Inductive sensors are applied directly in the measurements of magnetic field and indirectly in the measurements of linear and angular displacement and the measurements of protective coating thickness on ferromagnetic substrates.

Inductive sensors are typically fed by sinusoidal signals of various frequencies, depending on the kind of task performed. The signal can be composed of a number of sinusoids or it can be a deformed sinusoid, e.g. triangle-shaped, or sawtooth-shaped. Inductive sensors can consist of two windings, one of which is a generating winding and the other a measuring winding. If this is the case, then the signal to be examined comes from the measuring winding. It is possible for an inductive sensor to have one winding only, which performs the generating and measuring functions. In this case the analysis is carried out on the measuring signal whose parameters are subject to change during the measuring process [1, 2].

The measuring signal from the inductive sensor carries various kinds of information, e.g. on the thickness of outer protective coating, on its flaws as well as on linear or angular displacement. It is possible to estimate the condition of the object examined by analyzing the parameters of the measuring signal, since deviations in the signal usually correspond to the degree of deterioration in the object. The accuracy of the analysis is in this case a significant factor affecting the validity of the assessment of the object condition.

2 Analysis of a measuring signal in the DasyLab package

Integrated measuring environments are specialized programming packages, equipped with a number of specific task-oriented functions. In the case of programming environments it is an application, in the case of measuring environments it is software for controlling the operating system. In the programming environment there are a number of elements enabling or facilitating the application developing process, such as the implementation of the programming language (structural, graphical, or object language), editor, debugger, function library, extended help systems, etc.

Developing software of a measuring system involves manipulating graphical representations of objects, placed on virtual desktops, using the drag-and-drop method [3]. Performing an operation on such an object activates an event. The developer has to create a set of procedures for such events. The procedures are carried out by means of standard programming languages, such as C, or Basic, or by means of graphical languages.

Specialized programs enable not only analysis of signals from the measuring sensors but also simulation of such signals in the programming environment. The programs have to be fairly easy to install and to adapt to the user's preferences. These requirements are met by integrated measuring environments based on object programming, such as DasyLab produced by National Instruments [4].

The software is a significant part of the measuring systems which determines to what extent the potential of the hardware is exploited. It enables convenient control over the measuring process, recording and access to the data, which can be subsequently analyzed and processed. The results are presented in a suitable form. The DasyLab system enables the user to solve the problems of data acquisition and analysis in a holistic manner. Another advantage of the program is its simplicity: the analysis scenario is created by means of icons. Connections between icons represent the data flow and analysis. In this way, the data flow sheet is obtained.

The fact that it is easy to construct a measuring scheme with the types of analyses required and that it is possible to represent them in real time is also of great value. It only takes minutes to create one's own application for data acquisition and analysis by means of DasyLab. The analysis of complex acquisition and control problems is commonly used and does not require additional programming. The symbols of particular modules, representing input and output blocks, displays, and operations are simply to be placed in a Worksheet window and connected [5, 6].

Functional modules and functions are grouped by themes in DasyLab. The basic group are input-output modules. Here are found the elements responsible for acquiring the signal from the measuring card connected directly to the inductive sensor. The signal, typically a voltage one, is in the analogue form. The signal has to be subsequently modified by the signal processing modules so that it is suitable for analysis. It has to be amplified and filtered in order to eliminate interference and noise from the grid. The amplified and purified signal is the basis for establishing characteristic parameters of the measuring signal, such as amplitude, frequency, and phase of the fundamental harmonic, as well as for applying the functions of the FFT. By means of the statistical modules, it is possible to obtain average, minimal, and maximal values. It is also possible to draw a histogram of the input signal and determine the minimal and maximal values for a specific stream of data by prescribing the number of periods of the signal to be analyzed. The process of analyzing measuring signals from the inductive sensors can be controlled by means of controlling modules, which enable the starting and stopping of the analysis by the additional controlling signals, or by the operator. They also control the particular parameters during the analysis by means of various kinds of controllers acquiring data from external devices or by means of variables input to the system. The data processed and developed on the basis of signals from the inductive sensors can be represented in a graphical and numerical form as time characteristics, or as two-variable functions. The parameters which are relevant for the measurement can be input as analogue or digital indicators directly at any point of the analysis. The output data can be subjected to mathematical analysis to establish accuracy and eliminate measuring errors. There is yet another group of modules, the generating modules, for simulating the measuring signal. This is useful in the stage of constructing the system for measuring signal analysis, before the proper analysis begins [7].

3 Systems for recording and analysis of a measuring signal

In order to carry out the analysis of signals from inductive converters, a number of systems have been constructed for the use in laboratory experiments [8]. The diagram in Fig. 1 presents acquisition of two signals from the measuring card. One of them is a forcing signal from the sinusoidal signal generator and the other is the sensor's response to changes in the thickness of coating.

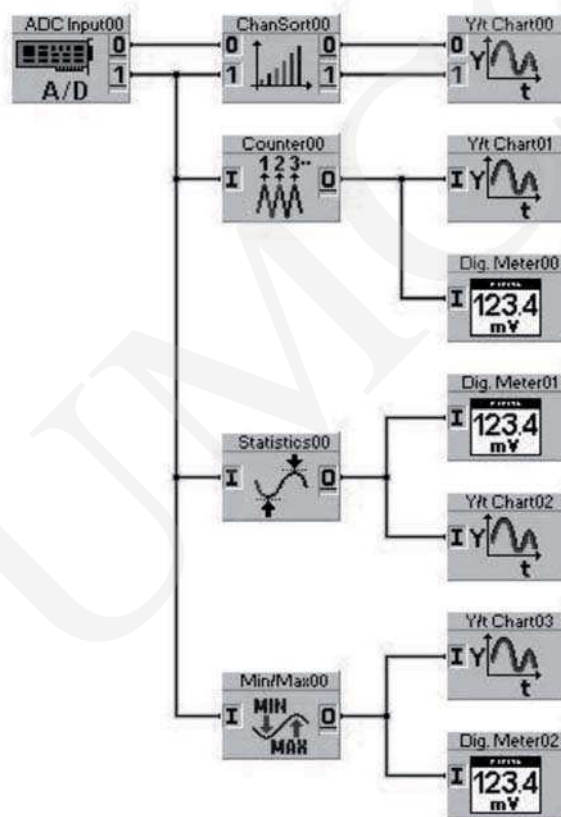

Fig. 1. Acquisition of signals from the inductive sensor and basic methods of their processing.

On the basis of the response signal from the inductive sensor, it is possible to establish the maximal, minimal, and average values in the analyzed signal, to carry out statistical analysis of these values and to obtain the frequency of occurrence of extreme values.

The diagram in Fig. 2 shows filtering of the signal received from the measuring card. This is done to eliminate interference of grid and radio frequencies.

The filtered signals are adjusted and combined into one signal, and then amplified, ordered, and brought to the oscilloscope, so that they can be visually represented.

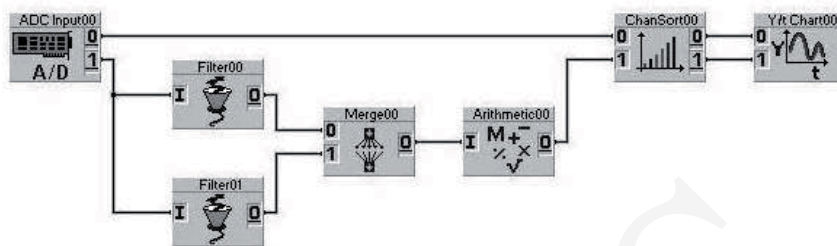

Fig. 2. Filtering, adjusting and amplifying the signal.

Fig. 3 offers a diagram of another system for analyzing the measuring signal. In this system, the selected measuring signals have their maximal and minimal values averaged. Besides, for these signals a prescribed block of measuring data is examined, for which the number of periods of the sinusoidal signal to be analyzed has been specified.

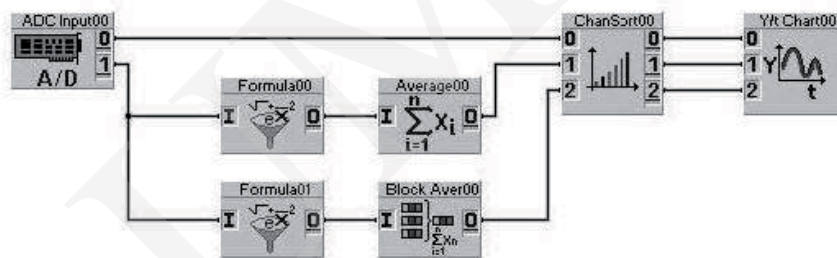

Fig. 3. Averaging and analysis of the maximal and minimal values of the measuring signal of the previously defined block of measuring data.

Fig. 4 illustrates various visualizations of signals from the inductive converter and their archivization by means of various methods. The measuring signal can be saved in a file for subsequent processing and analysis. It can be represented in a table as a sequence of values acquired from the sensor in certain time spans. It is also possible to represent the signal in a graphical way as waveforms of the forcing signal and the measuring signal in a single graph.

Fig. 5 presents an extended version of the system. Here, the solutions presented in the previous diagrams are combined to provide a holistic treatment of the signal acquisition, adjustment, amplification, analysis of the values characteristic of the sinusoidal waveforms, visualization and archivization so that it can be used as reference in further measurements and investigations of coating thickness.

The presented circuits can be also used in teaching technical subjects. Significant popularity of software packages allows you to increase students' interest about technical

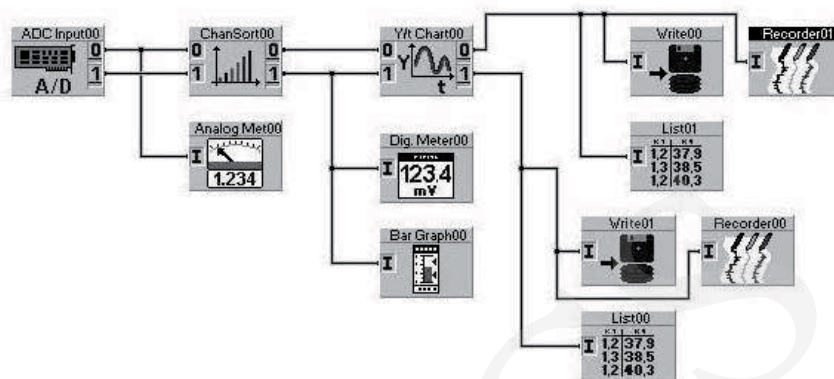

Fig. 4. Visualization and archivization of signals from the inductive sensor.

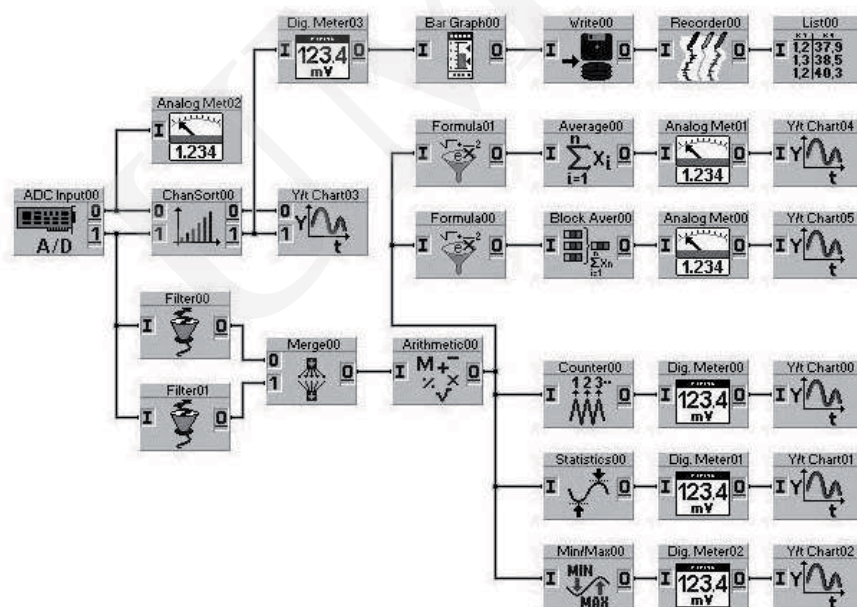

Fig. 5. Complete diagram of the system for analyzing signals from the inductive sensor.

education. This allows the use of such or similar programs for students to simulate the measurement processes in a university teaching lab [9, 10, 11].

4 Concluding remarks

The considerations presented above can be summed up in the following way:

- the DasyLab programming environment uses a graphical programming language therefore enabling developing a measuring system in the form of a diagram,
- particular elements and operations in the software package are represented as symbols connected in accordance with the direction of signal flow,
- the use of a measuring card ensures high accuracy of processing measuring signals,
- by means of the programming environment DasyLab it is possible to configure the existing measuring system, to develop an algorithm for signal processing on the basis of existing procedures and to build one's own graphic interface for representing the results of measurements and the results of measuring data processing,
- the developed system is an open and flexible solution, whose configuration can be extended and altered very quickly, to suit the current requirements of the user,
- the measuring system based on the computer measuring card is a tool of large potential and usefulness in metrology. It enables detailed analysis of the measuring signal from the inductive sensor, which, in turn, makes it possible to determine the coating thickness with high accuracy.

References

- [1] Lewińska-Romicka A., *Pomiary grubości powłok*, Biuro Gamma, Warszawa (2001).
- [2] Bronkiewicz A., Ptak P., *Wybrane aspekty metrologiczne metody pomiaru grubości warstw wierzchnich na podłożach ferromagnetycznych*, Materiały V Krajowej Konferencji PES-5 Postępy w Elektrotechnice Stosowanej, Zakopane-Kościelisko (2005): 283.
- [3] Kurkowski M., *Analiza sygnałów przy użyciu pakietu DasyLab*, XXXII MKM'2000, Rzeszów-Jawor, 11-15.09. 2000, Materiały T.2 (2000): 389.
- [4] Ptak P., *Metodyka analizy sygnałów w pomiarach grubości warstw wierzchnich*, Śląskie Wiadomości Elektryczne R.18 4(97) (2011): 44.
- [5] Winiecki W., *Graficzne zintegrowane środowiska programowe*, Wyd. Mikom Warszawa (2001).
- [6] Kurkowski M., Ptak P., *Charakterystyka oprogramowania systemów pomiarowych*, Zeszyty Naukowe Politechniki Częstochowskiej (2001).
- [7] Ptak P., *Pomiary grubości cienkich warstw na podłożu o innych właściwościach materiału niż warstwa wierzchnia*, Prace Komisji Naukowych, Zeszyt nr 33, Polska Akademia Nauk Oddział w Katowicach (2009): 128.
- [8] Ptak P., Prauzner T., *Wykorzystanie pakietu DasyLab w nauczaniu podstaw elektroniki*, Edukacja, Studia, Badania, Innowacje 02 (2010): 159.
- [9] Prauzner T., *Zastosowanie programów symulacyjnych w nauczaniu przedmiotów technicznych*, Prace Naukowe Akademii im. Jana Długosza w Częstochowie (2006): 121.
- [10] Ptak P., Prauzner T., *Rola i miejsce multimedialnych pomocy naukowych w edukacji technicznej*, Edukacja, Studia, Badania, Innowacje 02 (2010): 34.
- [11] Novotný, J., *The Way of Technical Popularization, Technical creativity in school's curricula*, Ljubljana, Narodna in univerzitna knjižnica (2011): 105.